

# **B600**

# **SCREW COMPRESSORS**

**20R/30R**



**13R/15L - 19R/22L**



**20R/30R SAE4**



**OPERATION**  
**MAINTENANCE**  
**SAFETY**



This Instructions only contains bare shaft machine information.

It is imperative to have in complement the accessories instructions, also the parts list before installing the equipment.

# MOUVEX TRUCK SCREW COMPRESSOR

## SAFETY, OPERATION AND MAINTENANCE INSTRUCTIONS

### MODEL : B600

#### SAFETY INFORMATIONS



#### This is a SAFETY ALERT SYMBOL

When you see this symbol on the product, or in the manual, look for one of the following signal words and be alert to the potential for personal injury, death or major property damage.



Warns of hazards that **WILL** cause serious personal injury, death or major property damage



Warns of hazards that **CAN** cause serious personal injury, death or major property damage.



Warns of hazards that **CAN** cause personal injury or property damage.

#### NOTICE

Indicates special instructions which are very important and must be followed.

#### REMARKS :

MOUVEX truck screw-type compressors **MUST** be installed in systems designed by qualified personnel. The installation **MUST** be in compliance with local standards, national regulations and rules of safety.

**This manual is designed to permit installation and commissioning of MOUVEX truck screw-type compressors and MUST accompany the compressor.**

**Maintenance of MOUVEX screw-type compressors must ONLY be carried out by qualified technicians. This maintenance must meet local and national standards as well as all safety regulations. Read this manual, including all instructions and warnings, in full BEFORE any use of MOUVEX compressors.**

**Do not remove the warning and use label stickers that are found on the compressors.**

#### TABLE OF CONTENTS

*Page*

<b>1. OVERALL DIMENSIONS</b> .....	<b>4</b>
<b>2. GENERAL DATA</b> .....	<b>7</b>
2.1 Principle of operation .....	7
2.2 Technical characteristics .....	8
2.3 Operating ranges .....	8
<b>3. MULTIPLIER 13R/15L - 19R/22L</b> .....	<b>10</b>
3.1 Cross-section .....	10
3.2 Multiplier mounting .....	11
<b>4. USE OF COMPRESSOR</b> .....	<b>13</b>
4.1 Lubricant recommendations .....	13
4.2 Filling of lubricant .....	14
4.3 Operation .....	14
4.4 Starting-up .....	14
<b>5. MAINTENANCE</b> .....	<b>15</b>
5.1 Maintenance schedules .....	15
5.2 Compressor oil change procedure .....	15
5.3 Troubleshooting .....	15

#### ADDITIONAL DOCUMENTATION

The table below gives the list of instructions in addition to this central instruction :

B600 application	Instructions	Spare parts list
20R/30R - SAE	NT 1401-Q00	PL 1401-Q02
13R/15L - 19R/22L	NT 1401-Q00	-
DDIC - DDNC	NT 1401-R00	PL 1401-R01
LS DDNC	NT 1401-W00	PL 1401-W01
Torque limiter	NT 1401-B00	-
Check and relief valve	NT 1401-E00	-

# SAFETY DATA

**⚠ WARNING**



Hazardous machinery can cause severe personal injury or property damage

IT IS IMPERATIVE TO APPLY THE TRUCK PARKING BRAKE AND TO BLOCK THE WHEELS BEFORE ANY INTERVENTION DUE TO RISKS OF SERIOUS BODILY INJURIES OR PROPERTY DAMAGE.

**⚠ WARNING**



Hazardous fluids can cause fire, serious personal injury or property damage.

COMPRESSING GASES INTO A VESSEL CONTAINING FLAMMABLE OR EXPLOSIVE GASES, OR COMPRESSING FLAMMABLE OR EXPLOSIVE GASES, CAN CAUSE PROPERTY DAMAGE, PERSONAL INJURY OR DEATH.

**⚠ CAUTION**



Hazardous pressure can cause personal injury or property damage.

FAILURE TO INSTALL ADEQUATELY SIZED PRESSURE RELIEF VALVE(S) CAN CAUSE PROPERTY DAMAGE, PERSONAL INJURY OR DEATH.

**⚠ CAUTION**



Extreme heat can cause injury or property damage.

COMPRESSOR, PIPING AND ACCESSORIES WILL BECOME HOT DURING OPERATION AND CAN CAUSE SERIOUS PERSONAL INJURY.

**⚠ WARNING**



Hazardous or toxic fluids can cause serious injury.

CONTENTS OF THE COMPRESSOR, TANK, PIPING, AND FILTERS COULD BE HAZARDOUS TO HEALTH. TAKE ALL NECESSARY PRECAUTIONS WHEN PERFORMING COMPRESSOR SERVICE OR MAINTENANCE.

**⚠ WARNING**



A loud noise can cause permanent body damage.

THE NOISE EMITTED BY WORKING MOVEX SCREW COMPRESSOR CAN BE HIGHER THAN 80 DBA. THE END USERS MUST USE, WHEN NECESSARY THE APPROPRIATE EAR PROTECTIONS. FAILURE TO WEAR HEAR PROTECTIONS IN AREAS WHERE THE NOISE IS HIGHER THAN 80 DBA CAN LEAD TO PERMANENT BODY DAMAGE.

## SAFETY CHECK LIST

1. Before operating the compressor, ensure the vessel to which the compressor is connected is certified to withstand the pressure and /or vacuum produced.
2. Verify adequately sized relief valves have been fitted to protect the vessel. Do not use solvents or inflammable products for cleaning the pipelines and the accessories.
3. Gas/air mixtures which are potentially volatile/explosive must not be introduced or allowed to be introduced into the compressor.
4. All pressure vessel and piping connected to the compressor must be isolated and in a safe operating condition.
5. Operators should wear ear protection when operating truck mounted compressors.
6. There are components within the compressor of sufficient weight to cause injury if mishandled. Use proper lifting devices as necessary.
7. Where necessary, this equipment should be grounded to control static electricity.
8. The temperature of the air leaving the compressor is elevated above ambient due to air compression. Check that the elevated temperatures do not adversely affect the product and any material used in design of the system. Attach clearly marked warning signs to warn of potentially hot surfaces on the compressor, piping and accessories which will burn if touched.
9. Mounting of the compressor must be correctly engineered and the compressor must be properly secured. Refer to the Compressor Mounting section of this manual.

## NOTICE :

MOVEX COMPRESSORS ARE NOT DESIGNED FOR HANDLING LIQUID, POWDER OR CONDENSATE. TO DO SO WILL VOID THE WARRANTY.

## LIFTING POINTS :

The compressor can be picked up from underneath to be transported.



Discharge flanges threads can be used to install a lifting lug in order to transport the compressor.



# 1. OVERALL DIMENSIONS

20R - 30R

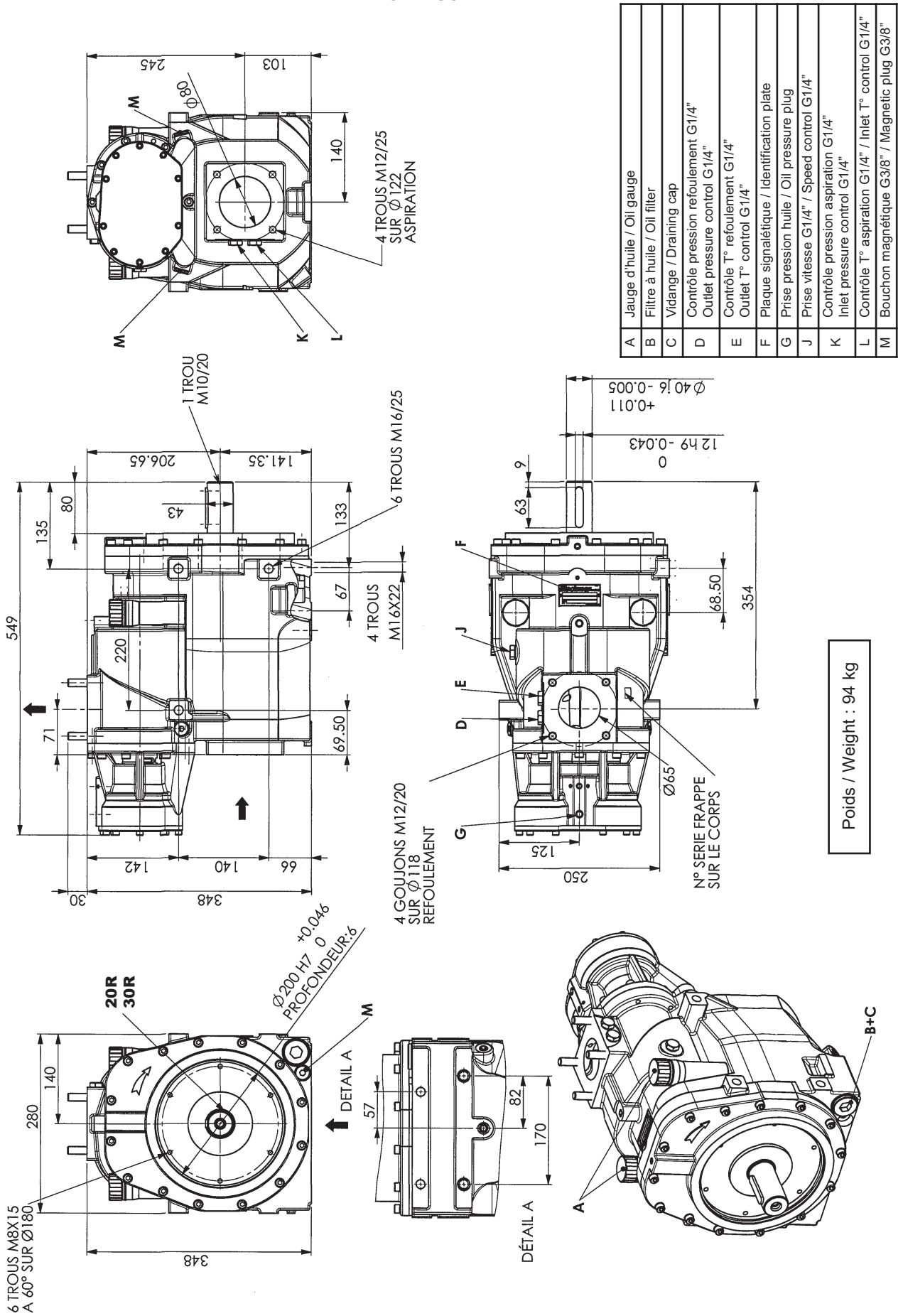

# 1. OVERALL DIMENSIONS (continued)

## 13R/15L - 19R/22L

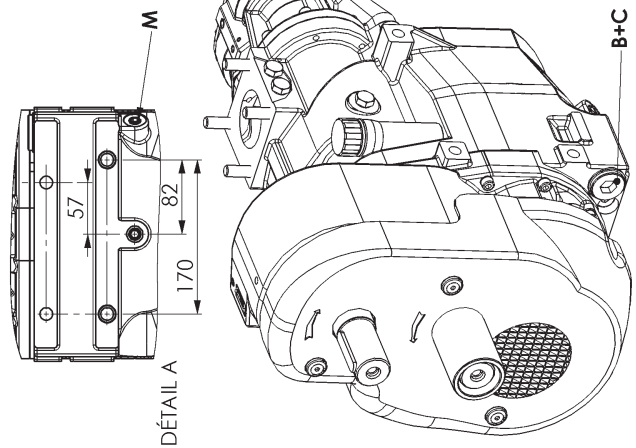
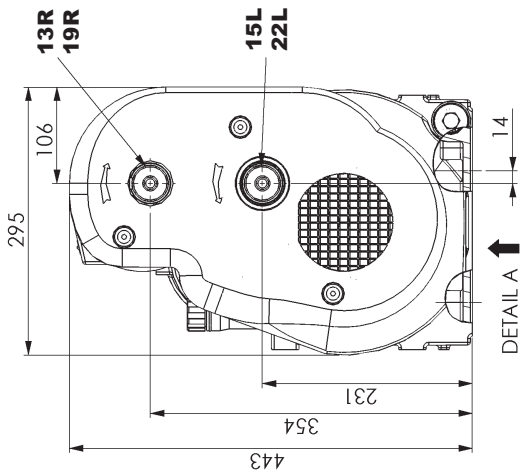
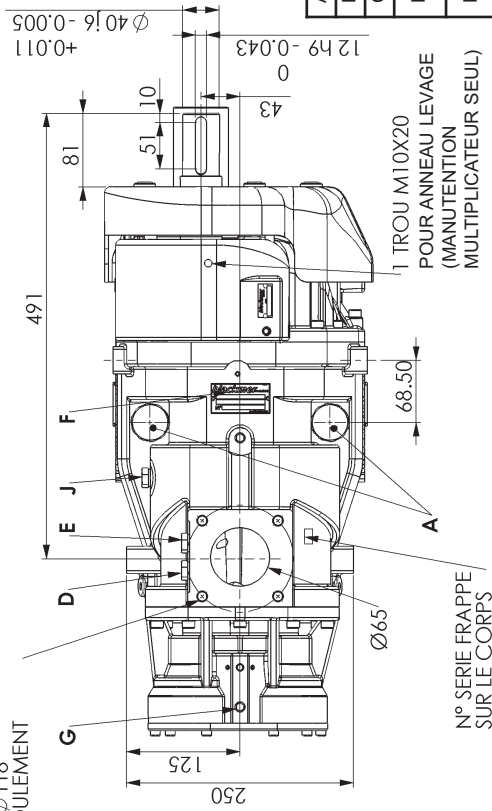
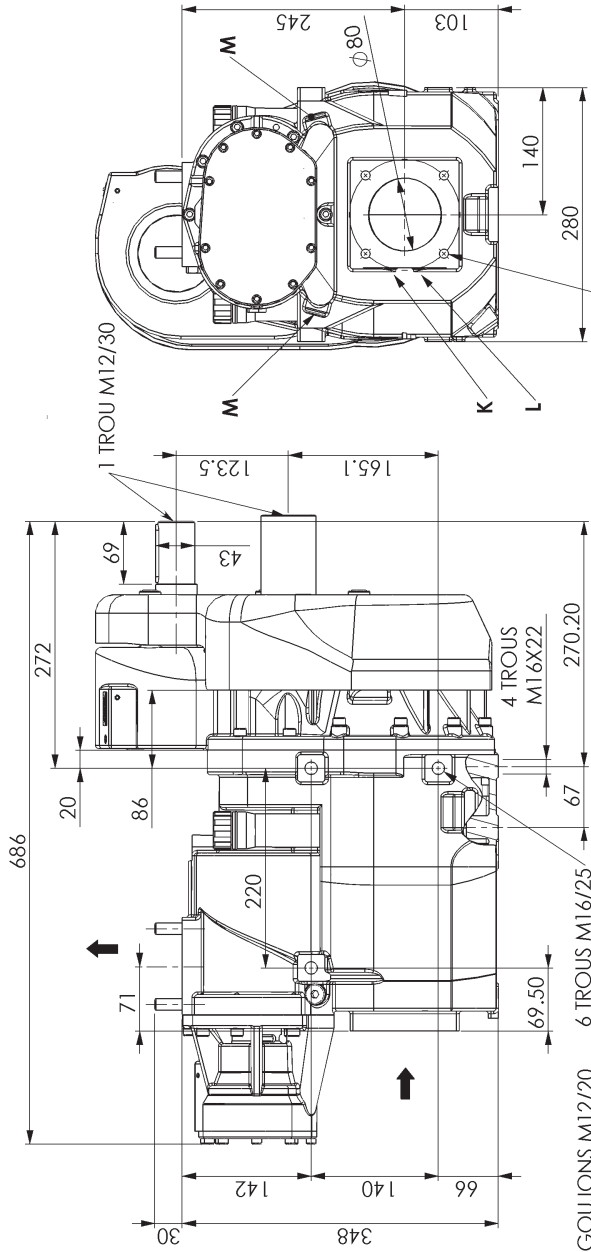

A	Jauge d'huile / Oil gauge
B	Filter à huile / Oil filter
C	Vidange / Draining cap
D	Contrôle pression refoulement G1/4"
E	Outlet pressure control G1/4"
F	Plaque signalétique / Identification plate
G	Prise pression huile / Oil pressure plug
J	Prise vitesse G1/4" / Speed control G1/4"
K	Contrôle pression aspiration G1/4"
L	Inlet pressure control G1/4"
M	Contrôle T° aspiration G1/4" / Inlet T° control G1/4"
	Bouchon magnétique G3/8" / Magnetic plug G3/8"

Poids / Weight : 124 kg

# 1. OVERALL DIMENSIONS (continued)

## 20R/30R SAE4

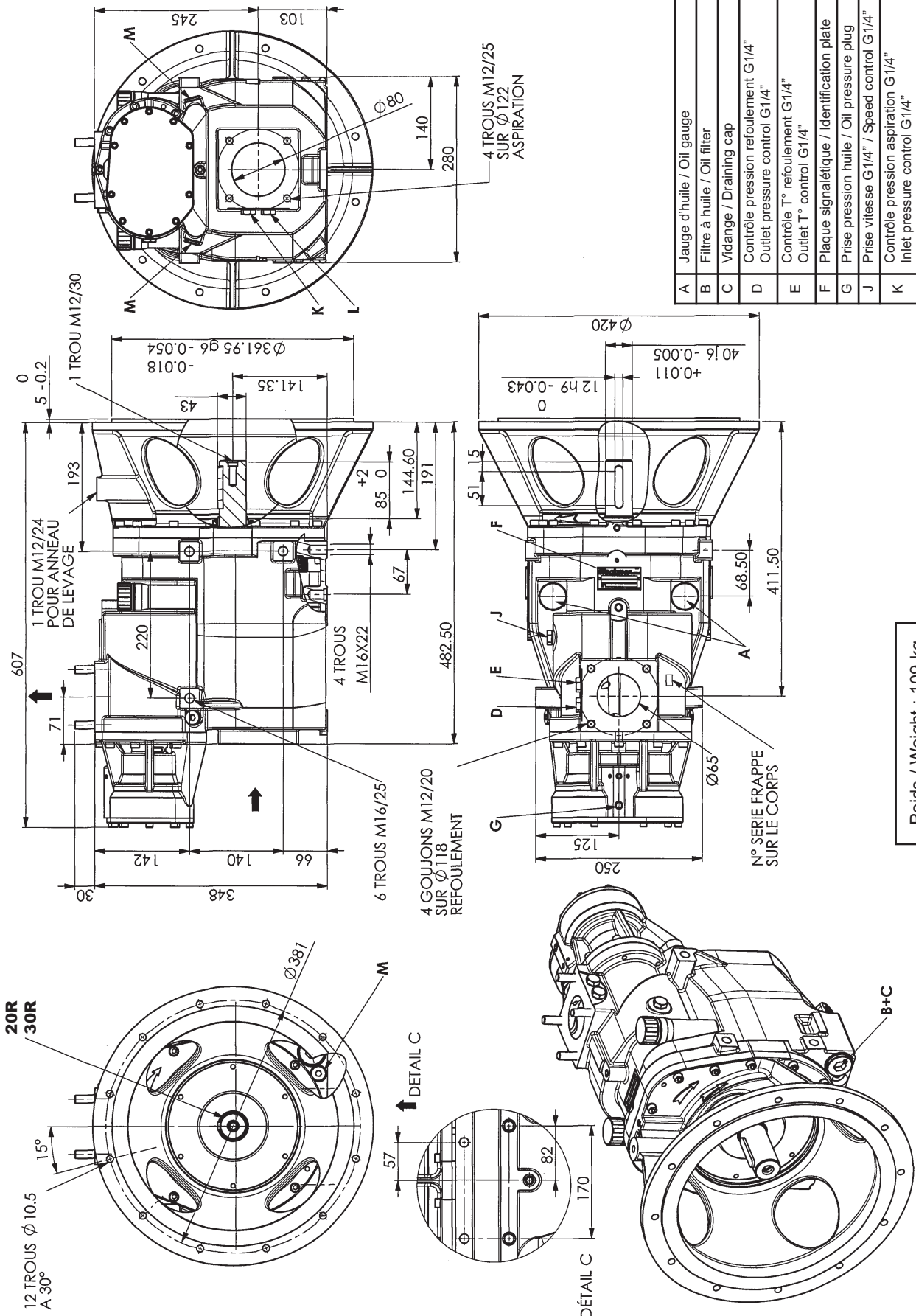

A	Jauge d'huile / Oil gauge
B	Filter à huile / Oil filter
C	Vidange / Draining cap
D	Contrôle pression refoulement G1/4" / Outlet pressure control G1/4"
E	Contrôle T° refoulement G1/4" / Outlet T° control G1/4"
F	Plaque signalétique / Identification plate
G	Prise pression huile / Oil pressure plug
J	Prise vitesse G1/4" / Speed control G1/4"
K	Contrôle pression aspiration G1/4" / Inlet pressure control G1/4"
L	Contrôle T° aspiration G1/4" / Inlet T° control G1/4"
M	Bouchon magnétique G3/8" / Magnetic plug G3/8"

Poids / Weight : 109 kg

## 2. GENERAL DATA

### 2.1 Principle of operation

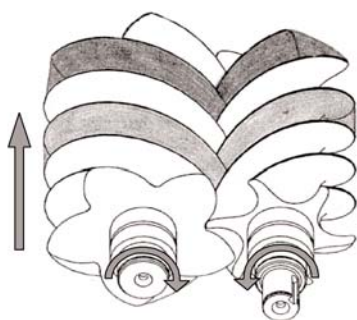

The male screw and the female screw mesh and rotate in opposite directions inside the casing fitted with inlet and discharge ports.

Rotation generates a volume increase on the inner face between threads and grooves, which corresponds to inlet, and a volume reduction on the upper face, which corresponds to compression.

On the discharge port side, a set of gears synchronizes the male screw and the female screw. Thus, the screws are not in contact. The discharged air does not enter in contact with any friction part and remains clean and free from particles.

On the drive shaft side, the female screw is driven by a set of step-up gears.

An oil pump delivers pressurized oil which circulates, lubricating gears and ball bearings.

Sealing is provided between lubricated parts and the compression stage by means of labyrinth seals. These seals do not enter in contact with the shaft and are not subject to wear.

Thanks to their technology, B600 compressors are reliable and have a long service life.

B600 compressors need very limited maintenance, which reduce vehicle downtime.

B600 version 20R, 13R/15L and 19R/22L drive speed were defined so as to drive it directly through universal joints from a P.T.O. shaft. B600 compressor is therefore fitted within the chassis. Thanks to this system, the installation is lighter and saves space on the side of the vehicle for other accessories.

B600 version 30R can be directly driven by an electric or hydraulic motor, and can be driven by a diesel motor if this motor can be disengaged at its start and at its stop.

The 20R and 30R versions may be fitted with a SAE4 flange so that they can be mounted on diesel engines.

#### CAUTION

**Our packages are delivered without oil. The use of a compressor with an oil level that is not located between the two limits indicated by the gauge can lead to important property damage and serious injuries.**

## 2. GENERAL DATA (continued)

### 2.2 Technical characteristics

The operating characteristics are given in the indicative operation conditions : ambient temperature and air inlet temperature 20°C, atmospheric pressure : 1013 mbars.

Speed (rpm) :

B600	1	2	3	4	5
13R	780	910	1040	1170	1300
15L	900	1050	1200	1350	1500
19R	1170	1365	1560	1755	1950
20R	1200	1400	1600	1800	2000
22L	1320	1580	1800	2035	2250
30R	1800	2100	2400	2700	3000
Maximum discharge pressure (inlet suction air at 20°C)	2	2,3	2,5	2,5	2,5

### 2.3 Operating ranges

The operating ranges specified in the § TECHNICAL CHARACTERISTICS give the conditions that must be respected on mounting and packaging of the B600 compressors, in order to be able to benefit from the guarantees for these pieces of equipment.

### 2.3.1 CONDITIONS AT SUCTION

	Maximum temperatures and pressures			
Speed (rpm) B600 N-20R	1200	1600	1600	2000
Speed (rpm) B600 N-30R	1800	2400	2400	3000
Speed (rpm) B600 N-19R/22L, driving by shaft 22L	1320	1800	1800	2250
Speed (rpm) B600 N-19R/22L, driving by shaft 19R	1170	1560	1560	1950
Speed (rpm) B600 N-13R/15L, driving by shaft 15L	900	1200	1200	1500
Speed (rpm) B600 N-13R/15L, driving by shaft 13R	780	1040	1040	1300
Discharge pressure of compressor (bar)	2,0	2,0	2,5	2,5
Maximum inlet temperature allowable at this pressure (°C)	40	45	28	35

The compressor inlet suction air must be filtered in order to eliminate particles bigger than 5 µm.

The maximum pressure drop at suction must be lower than 75 mbar.

A clogging indicator system must permit changing the suction filter when it creates a pressure drop greater than 75 mbar.

The maximum acceptable temperature at suction as a function of equipment operating conditions is given in the § TECHNICAL CHARACTERISTICS.

### Characteristics of bare shaft end compressor and direct drive package :

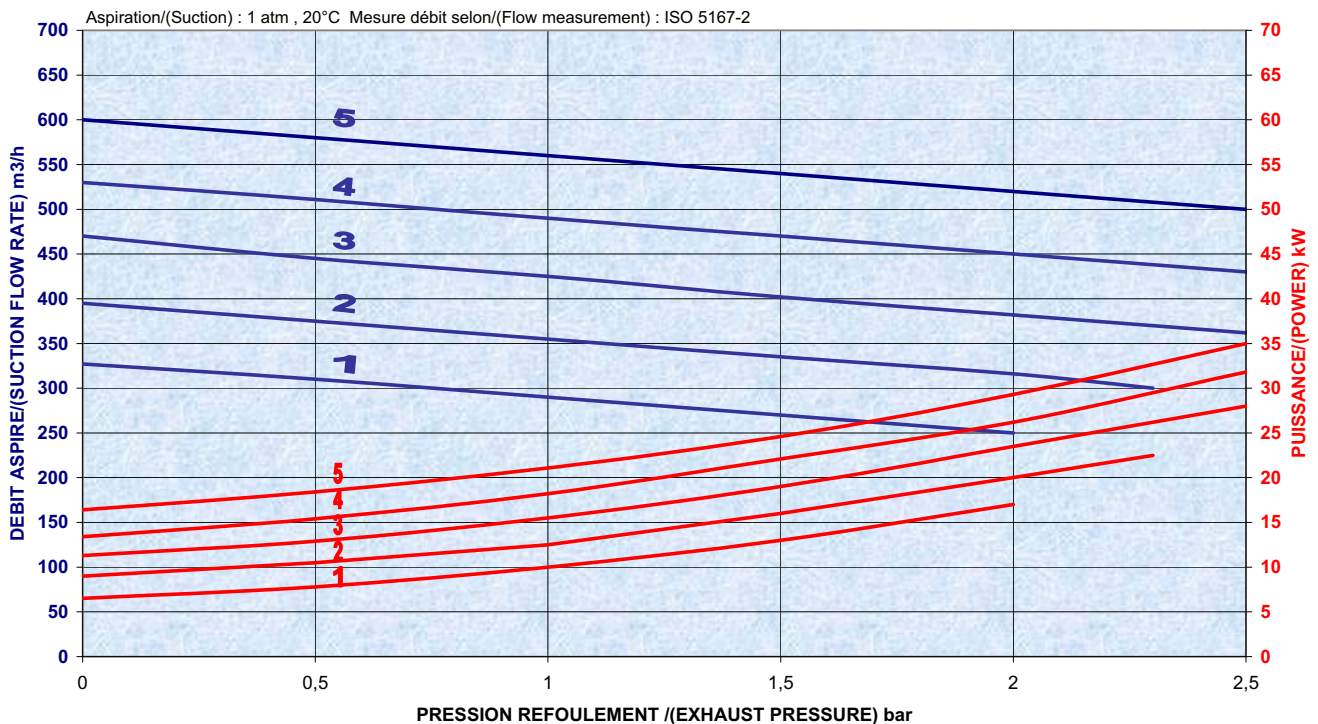



## 2. GENERAL DATA (continued)

### 2.3.2 CONDITIONS AT DISCHARGE

The B600 compressor must be protected by a valve that protects the compressor against accidental over-pressure.

See Instructions 1401-E00 SCREW COMPRESSORS CHECK AND RELIEF VALVE.

Maximum acceptable discharge pressure : see § TECHNICAL CHARACTERISTICS.

The pressures correspond to the valve opening start pressure. In a period of 60 seconds, it is acceptable to have a pressure of 0,2 bar higher when the valve passes the complete flow rate.

### 2.3.3 RECOMMENDED DRIVE CONDITIONS

#### Operating torque at full speed (Nm)

B600	Pressure (bar)		
	1,5	2,0	2,5
13R	180	210	260
15L	160	180	220
19R	120	150	170
20R	120	140	170
22L	110	130	150
30R	80	95	110

The transmission lines (universal joint, pulley belt, etc.) must be sized so as to be able to accept the loads above and also the starting torque and protected by an appropriated system.

**Direct drives must be protected by a set torque limiter (see Instructions 1401-B00 TORQUE LIMITER - SCREW COMPRESSORS).**

It is the responsibility of the designers of other packages to check that their design protects the transmission (and in particular the universal joint on the truck) if the compressor blocks.

In any case where the compressors are to be driven by diesel motor, the system must be able to disengage the compressor at equipment start up and stop.

It is imperative that the drive shafts be dynamically balanced.

#### CAUTION

**The non balancing of the drive shafts can lead to mechanical ruptures that are susceptible of causing important property damage and/or serious injuries.**

The shafts of the motors driving the B600 compressors must be aligned within one angle degree on the B600 shaft.

In the case universal joint drive, the motor and compressor side shafts must be parallel within one degree. The universal joint plates must be parallel within one degree. Specific installation conditions : See Instructions 1401-Q00 DDK BARE SHAFT END FOR TRUCK INSTALLATION - § PTO SHAFT DRIVE.

#### CAUTION

**Not following assembly instruction can lead to mechanical ruptures that may create major property damage and/or serious injuries.**

### 2.3.4 ACCEPTABLE OIL PRESSURE RANGE

The oil pressure is measured at the tap point located on the synchromesh gear box (item G on the outline drawings) :

B600	Mini pressure (bar)	Maxi pressure (bar)
20R	0,2	3,0
30R	0,2	3,8
13R 15L	0,2	3,0
19R 22L	0,2	3,8

#### CAUTION

**In operation, the surface temperature of a compressor and parts close to him may reach high temperatures liable to cause significant burns and inflammation of materials.**

#### CAUTION

**Having the compressor run above its maximal temperature may lead to serious body injuries or property damages.**

### 3. MULTIPLIER 13R/15L - 19R/22L

#### 3.1 Cross-section

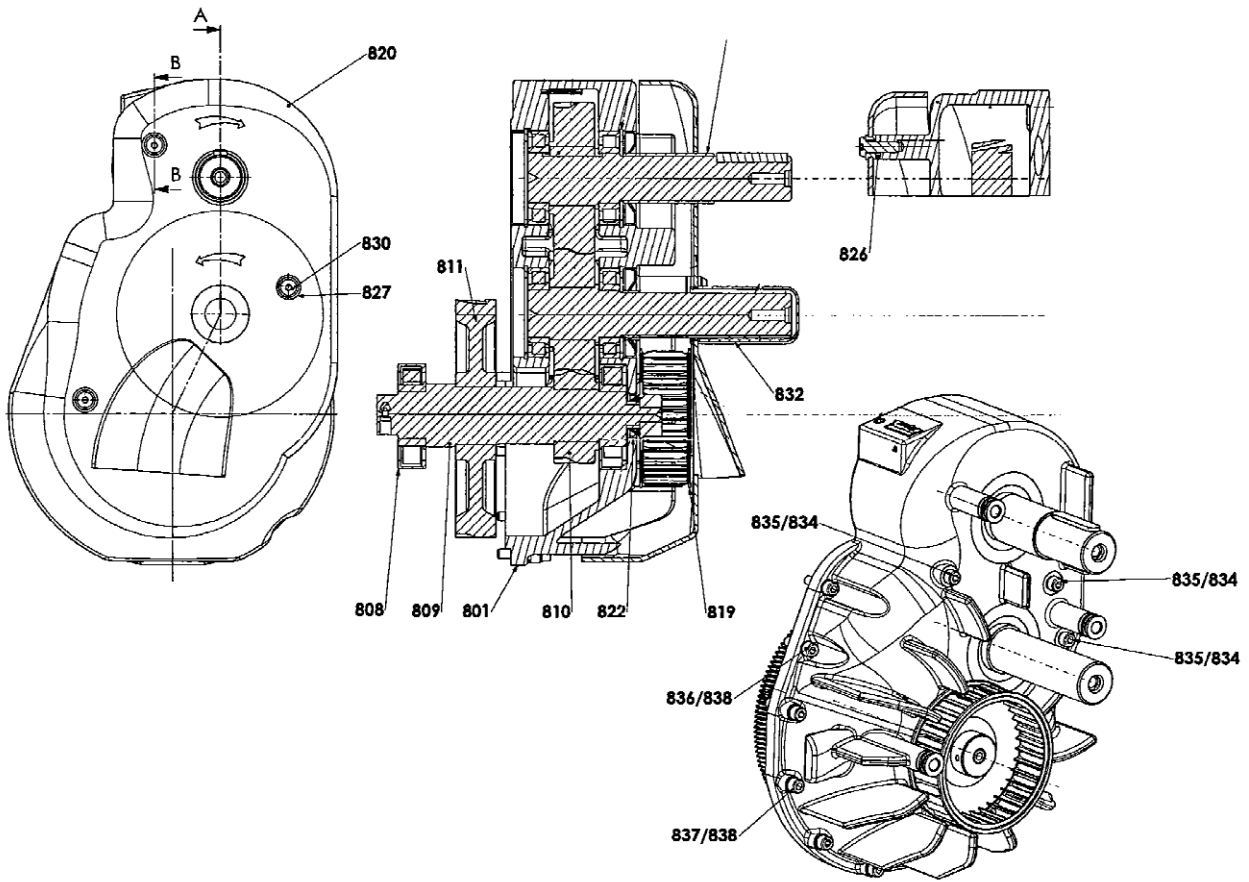

Front view of compressor

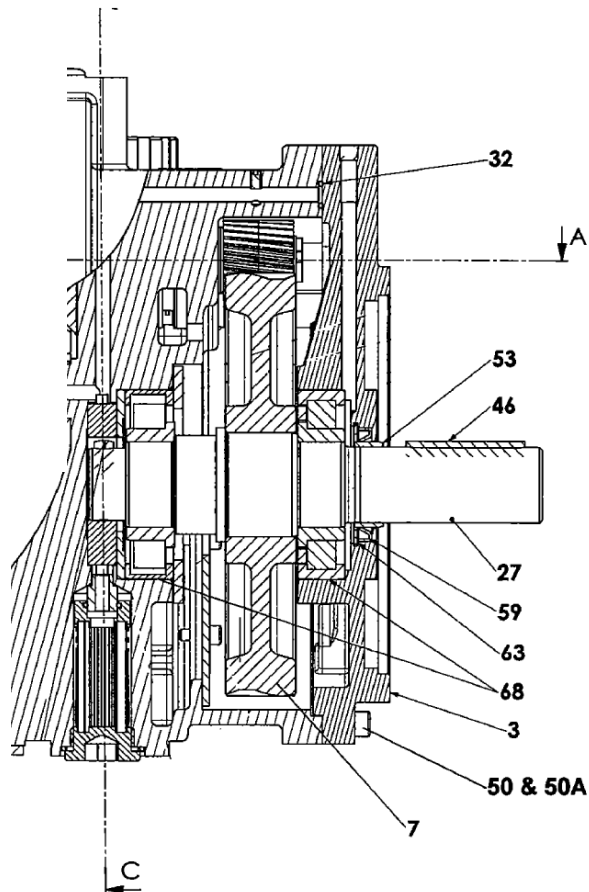

## 3. MULTIPLIER 13R/15L - 19R/22L (continued)

### 3.2 Multiplier mounting

#### **⚠ WARNING**

Bold references return to marker numbers cross-sections at the end of the assembly procedure.

Belt pulley packages may not use a multiplier.

To mount a multiplier :

- \* 13R/15L on a compressor N20R or
- \* 19R/22L on a compressor N30R,

the following sequence of operations must be respected :

- When the multiplier and the group made up of the shaft **809** with its gears **810** and **811** and inner bearing rings **808** are delivered separately from the compressor, the screws **830**, **835**, **836** and **837**, the washers **838**, the washers **827** and **834**, cover **830+832**, lipseal **822**, the fan and its screw **819**, as well as the group made up of the inner ring of the 2 bearings **808**, gears **811** and **810** and shaft **809** are delivered packaged separately. Remove the key **46** and the spacer **831** from the from the drive shaft before starting to assemble.
- Prepare the compressor N20R or N30R from MOUVEX :
  - Drain the compressor oil.
  - Install the compressor as shown in the photo below, its body sloping at least 30°.



- If necessary, remove the torque limiter.
- Remove the key **46**.
- Remove the screws **50** and the washers **50 A** holding the lid in place **3**.
- Remove the lid **3** and the seal **59**. The shaft will be held in place as the compressor slopes. If necessary, use 2 screws M10 to extract the lid.
- Remove from a block the shaft **27**, ring **53**, circlips **63**, gear **7**, a complete roller bearing **68**, the inner ring of the second roller bearing **68**. If necessary, use the tappings M8 found top right and bottom left of the lid to extract the lid.
- Scrape the Loctite® 510\* remaining on the joint surface on the compressor side **1**.

- Check that the seal **32** is in place on the compressor body. If necessary, hold it in place using a little grease.

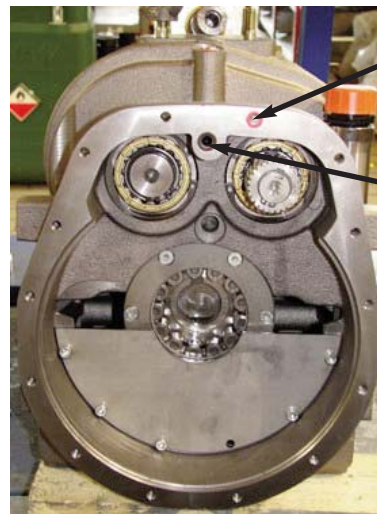

Headless screw **839** mounted with Loctite® 510\*

Be careful to the seal **32** (keep it in place)

The multiplier may be handled using a lifting ring in the thread M10 in the multiplier.

- Mount the multiplier on the compressor :
  - Mount the headless screw **839**.
  - To mount the shaft, in particular in the oil pump, align the oil pump drive recess on the high vertical.
  - Firstly, mount in the compressor the group made up of the shaft **809** fitted with its gears **810** and **811** and the inner bearing rings **808**. Make sure you engage the shaft pin in the recess of the oil pump **809**. Engage at the end the inner bearing cage **808**, screwed to the shaft, in the bearing **808** inside the compressor.

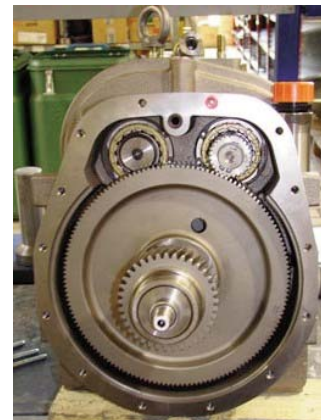

- Push the outer cage and the roller of the bearing **808** still in the multiplier to the end.

\* Loctite® is a registered trademark.

### 3. MULTIPLIER 13R/15L - 19R/22L (continued)

- Coat the surface for contact between the body and the multiplier with Loctite® 510\*.

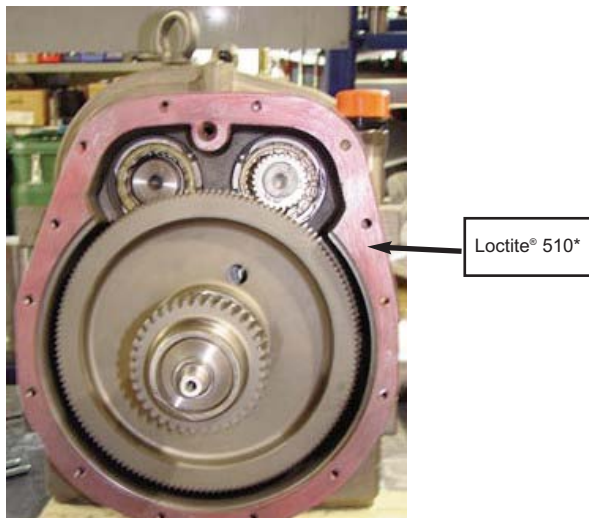

- Mount the fan **819** and screw up the relevant screw to screw it to the shaft **809**. NB the fan wings can cut ; use suitable protection. Wipe off the excess Loctite®\*.

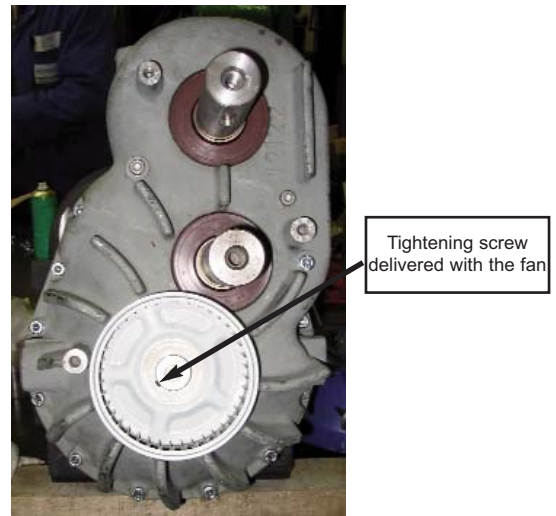

- Grease the lip joint **822**.
- Centre the shaft **809** in the bearing **808** and engage the lip joint **822**, and, in the same movement, engage the centring between the compressor and the multiplier.
- Place Loctite® 243\* on the short screws **836** and washers **838** keeping the body of the multiplier in place **801**. Screw at torque  $24 \text{ Nm} \pm 10\%$ . Start screwing with the 2 opposite screws, screwed gradually, ckecking that the multiplier drive shafts can rotate freely.



- On the cover **820**, check the presence of spacers **826** in the sleeves **827**.
- If necessary, depending on the drive shaft, change the shaft position protector **832**.
- Put the cover **820** in place.
- Place Loctite® 243\* on the screws **830** through the sleeve **827** and the spacer **826** to hold the cover **820** in place. Screw at torque  $24 \text{ Nm} \pm 10\%$ .
- Engage the spacer **831** on the multiplier drive shaft.
- Mount the key.
- If necessary, replace the torque limiter.

- Place Loctite® 243\* on the screws **837** and washers **838** keeping the body of the multiplier in place **801**. Screw at torque  $24 \text{ Nm} \pm 10\%$ . Check that the multiplier drive shafts rotate freely.
- Place Loctite® 243\* on the screws **835** and rings BS **834** keeping the lid in place **3**. Screw at torque  $24 \text{ Nm} \pm 10\%$ .
- Unscrew the screw holding the fan in place **819**. Inject a drop of Loctite® 243\*. Replace the screw.

\* Loctite® is a registered trademark.

## 4. USE OF COMPRESSOR

The operator should remain nearby the equipment throughout the use to ensure the proper functioning of the system.

### 4.1 Lubricant recommendations

MOUVEX BSC oil is recommended for 20R and 30R configuration, whereas it is imperative for 13R/15L and 19R/22L.

A start up oil change has to be made after one week or 10 working hours. Not performing this oil change will void the warranty.

For the first week or 10 working hours, you can choose a standard mineral oil. The standard mineral oil grade will be selected according to the ambient temperature under which the compressor will be operated :

- Below -10°C . . . . . SAE 10 W 40
- Between -10°C and 30°C . . . SAE 15 W 40
- Above 30°C . . . . . SAE 15 W 50

With BSC oil, oil change is recommended every year or 500 working hours.

BSC oil used with compressors fitted with MOUVEX 13R/15L and 19R/22L multipliers must be changed each 9 months or after 300 working hours.

B600	BSC oil		
	First oil change (h)	Oil change	Warranty period (year)
20R - 30R	10	500 h / 1 year	3
13R/15L	10	300 h / 9 months	3
19R/22L	10	300 h / 9 months	3

**⚠ CAUTION**

In case of operations done **under minus 10°C**, BSC oil viscosity sharply increases and can generate starting troubles.

In order to avoid these troubles, we suggest 2 alternatives :

- To warm up the compressor's housing before starting.
- To replace temporarily our BSC oil by standard oil SAE 10W40.

SAE 10W40 oil draining frequency must not exceed 100H and must be limited to a seasonal using.

**BSC oil will have to be moved back as soon as the temperature average level goes back up to minus 10°C, otherwise our warranty is void.**

Compressors may be used with an external cooler ; ask for plan 61699 from MOUVEX technical support for further details.

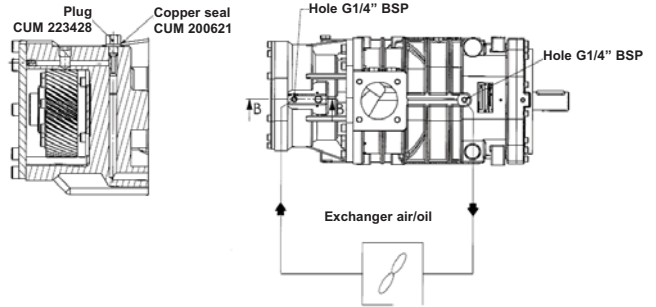

If the connection marked on the joint view has 6 hollow surfaces, the compressor is designed to operate without an external cooler. If the connection marked on the joint view has a hexagonal head, the compressor is designed to operate with an external cooler.

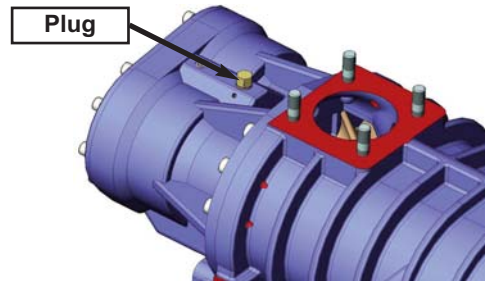

**⚠ CAUTION**

**Depending on the type of cooling, using the wrong screw will quickly lead to damage, not covered by the warranty, to the compressor and may lead to serious injury and/or serious damage to equipment.**

## 4. USE OF COMPRESSOR (continued)

### 4.2 Filling of lubricant

#### ⚠ CAUTION

Our packages are delivered without oil. The use of a compressor with an oil level that is not located between the two limits indicated by the gauge can lead to important property damage and serious injuries.

The quantity of oil for each compressor is approximately :

- B600 20R - 30R. . . . . 4,2 l
- B600 13R - 15L . . . . . 4,8 l
- B600 19R - 22L . . . . . 4,8 l

Before starting the system, fill the casing with oil so that the oil level is set between the min and max value of the gauge.

NB : A residual volume of 0,5 l of oil may be present inside the compressor when it leaves the factory.

After filling, the level must under no circumstances exceed the maximum marker on the oil gauge (the level is taken after the gauge has been completely screwed onto the filling tube).

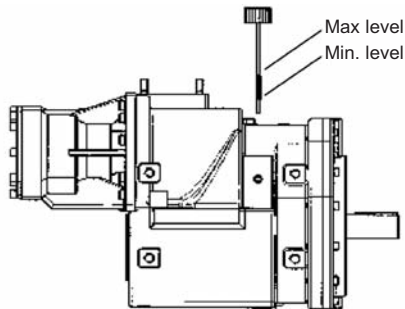

### 4.3 Operation

- The compressor must be started with the discharge valves open.
- When it is started for the first time, check the compressor rotation direction. Also check rotation speed (refer to § TECHNICAL CHARACTERISTICS).
- The compressor shall be stopped without any counterpressure at discharge.
- At the first start, check that the combinations of rotation speed and discharge pressure of the compressors are in conformity with those indicated in § TECHNICAL CHARACTERISTICS.

#### ⚠ CAUTION

Before any equipment startup, it is necessary to check the coherency between the motor rotation direction and the compressor operating direction. A startup with rotation in the wrong direction will lead to irreversible property damage on the compressors that is not covered by the guarantee.

#### ⚠ CAUTION

During operation, the temperature of the surface of a compressor and nearby parts can be in the region of 200°C. The compressor and the parts located nearby are thus susceptible of provoking serious burns and property damage. Be careful to not approach elements that are sensitive to heat and affix plates informing users that the compressor is hot, to prevent any risk of burns.

### 4.4 Starting-up

BEFORE starting compressor, open all air valves necessary to vent the tank and compressor to atmosphere.

Verify there is no possibility of operating at pressure before compressor reaches correct speed.

OPEN



Close all valves and proceed to pressurize the tank and discharge the cargo.

CLOSE

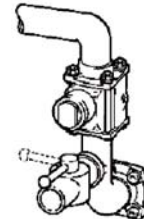

#### NOTICE :

COMPRESSOR MUST OPERATE AT FIXED SPEED WITHIN THE COMPRESSOR MODEL SPEED LIMITS. SPEED MUST REMAIN CONSTANT THROUGHOUT THE OFF LOADING OPERATION.

# 5. MAINTENANCE

## 5.1 Maintenance schedules

### After every cleaning of the truck

Always run the compressor for 15 minutes to remove any water that inadvertently gets into the piping. DO NOT fog or introduce anti-corrosive liquids into the compressor to prevent corrosion : Use of liquids in the compressor will cause failure.

### After first 10 hours or first week operating

Change the compressor oil and clean the magnetic plugs.

### According to the prescriptions of § LUBRICANT RECOMMENDATIONS.

Change the compressor oil and clean the magnetic plugs.

### Weekly

The compressor should be run for at least 15 minutes to prevent moisture from collecting inside. This will reduce the risk of corrosion damage to the compressor and other equipment in the piping.

Clean the outer surfaces and the compressor cooling wings, and the multiplier inlet grille. Inspect DAILY if operating in dirty or severe environment. Check the condition of the inlet filter hose for splits and tears. Replace or repair as necessary.

Inspect compressor, system piping and components. Clean or repair as necessary.

### Monthly

Check oil level, add the necessary volume if necessary. Check for cleanliness the breather inside the oil gauge, clean with an air blower if necessary.

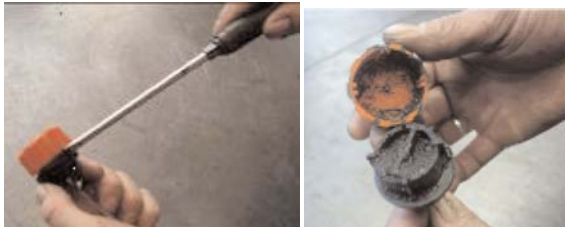

THE BLOWING OF OIL GAUGE CAN CAUSE PERSONNAL INJURY OR PROPERTY DAMMAGE. IT IS MANDATORY TO CARRY APPROPRIATE PROTECTIONS (GLOVES, GLASSES...) TO AVOID RISKS OF PERSONNAL INJURY.



## 5.2 Compressor oil change procedure

Oil gauge : See § LUBRICANT RECOMMENDATIONS.

Unscrew and remove the oil filter with its seal (marked C on the outlines drawings). Drip-drain all the oil contained in the casing.

Carefully clean the oil filter with solvent. Blow out all impurities with a compressed air blast.

Clean the magnetic plugs (marked M on the outlines drawings).

After checking that no particles remain in the filter, reinstall it making sure that the seal is in good condition. Fill the compressor. See § FILLING OF LUBRICANT.

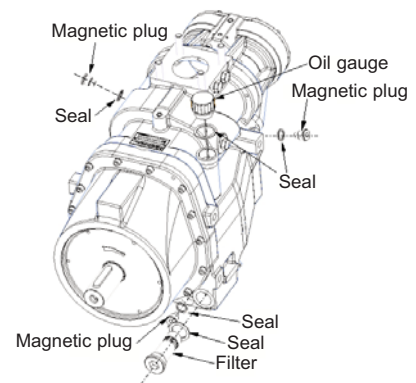

## 5.3 Troubleshooting

See Instructions 1401-Q00 DDK BARE SHAFT END FOR TRUCK INSTALLATION - § TROUBLESHOOTING.